

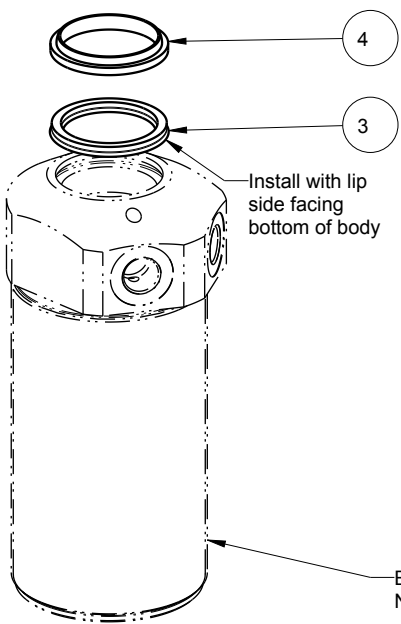

NO	QTY	PART NO	DESCRIPTION	STD SEAL KIT	FKM SEAL KIT
1	1	30601130	ASSY, PLUG, SOCH, SAE 3		
2	1	39011056	SEAL,CROWN,1-9/16x1-3/4x5/32	X	39V11056
3	1	39011060	SEAL,BEVEL W/HEEL INSERT,1-1/4 x1/8 x1-1/2	X	39052015
4	1	39053005	WIPER,SNAP-IN, (1-1/4)	X	X
5	1	47511800	PLUNGER, SC, 22 KN		
6	1	81531800	RETAINER, SC, 5000		
7	1	39T55004	GASKET, (-134)	X	X
N/A	N/A	46250203	KIT, SEAL, CYL, PP, TB, DA, 53.3KN	NOTED	N/A
N/A	N/A	6V250206	KIT, SEAL, CYL, PP, TB, DA, 53.3KN, FKM	N/A	NOTED

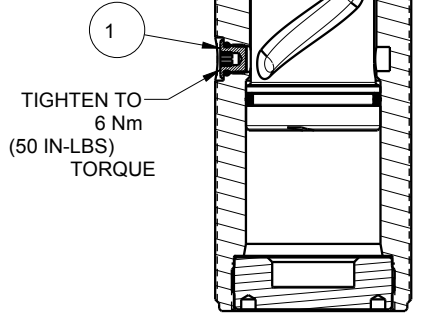

Lubricate all seals with clean hydraulic fluid prior to assembly

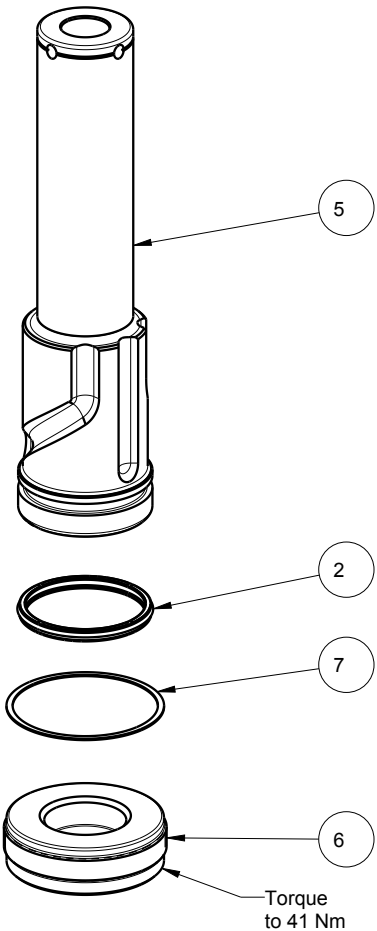

<b>PARTS LIST</b>	 VEKTEK, INC. 1334 E. SIXTH AVE. P.O. BOX 625 EMPORIA, KS. 66801 U.S.A.																			
	ASSEMBLIES AFFECTED 42-5028-00																			
<table border="1"> <tr> <td>REV</td> <td>IN ACCORDANCE WITH ECN</td> <td>EFFECTIVE DATE</td> <td>REVISED BY</td> <td>DATE</td> </tr> <tr> <td>DRW BY: MAJ</td> <td colspan="3">DRAWING STATUS: <b>Released</b></td> <td>SIZE A</td> </tr> <tr> <td>DATE: 5-8-17</td> <td colspan="3">PRODUCTION APPROVED FOR RELEASED STATUS ONLY</td> <td>REV B</td> </tr> </table>	REV	IN ACCORDANCE WITH ECN	EFFECTIVE DATE	REVISED BY	DATE	DRW BY: MAJ	DRAWING STATUS: <b>Released</b>			SIZE A	DATE: 5-8-17	PRODUCTION APPROVED FOR RELEASED STATUS ONLY			REV B	<table border="1"> <tr> <td colspan="2">PARTS LIST, ASSY, CYL, PP, TB, 53.3KN</td> </tr> <tr> <td>FORM FEG035_PL_ASIZE, REV. B</td> <td>SHEET 1 OF 1</td> </tr> </table>	PARTS LIST, ASSY, CYL, PP, TB, 53.3KN		FORM FEG035_PL_ASIZE, REV. B	SHEET 1 OF 1
REV	IN ACCORDANCE WITH ECN	EFFECTIVE DATE	REVISED BY	DATE																
DRW BY: MAJ	DRAWING STATUS: <b>Released</b>			SIZE A																
DATE: 5-8-17	PRODUCTION APPROVED FOR RELEASED STATUS ONLY			REV B																
PARTS LIST, ASSY, CYL, PP, TB, 53.3KN																				
FORM FEG035_PL_ASIZE, REV. B	SHEET 1 OF 1																			